

Zebra

Two-Stage Rotary Vane Vacuum Pumps RH 0030–0090 B



- › **Efficient**
- › **Reliable:**
robust construction, proven technology, reliable operation
- › **High Performance:**
stable pumping speed even in low pressure range
- › **Quiet Operation**
- › **Easy Servicing**

Zebra two-stage rotary vane vacuum pumps have been designed to suit the requirements of a wide range of applications, from research labs to production lines.

Robustness and reliability of operation are the outstanding qualities of Zebra rotary vane vacuum pumps. These are just some of the reasons why proven Busch rotary vane technology has long established itself as the industry standard. Millions of Busch rotary vane vacuum pumps are in operation world-wide in industry every day. With the Zebra series, Busch also offers two-stage rotary vane vacuum pumps for applications in the medium vacuum range.

The constant vacuum level in continuous operation is ensured by forced oil lubrication, perfectly coordinated materials as well as state-of-the-art precision manufacturing. Its

quiet operation makes the Zebra vacuum pump series perfectly suited for use in research labs, where a low-noise working environment is essential. The advanced design ensures that only minimal maintenance is required.

Applications

- Laboratory
- Distillation/Extraction
- Filtration/Solvent recovery
- Analytical instruments – GCMS
- Backing pump for turbomolecular and diffusion vacuum pumps
- Electron microscopes
- Leak detectors
- Vacuum drying, freeze-drying (lyophilization)
- Refrigeration and air conditioning
- Load locks and transfer chambers
- Coating equipment

Zebra – reliable medium vacuum for demanding applications in industry and research.



Zebra

Two-Stage Rotary Vane Vacuum Pumps RH 0030–0090 B



Zebra RH 0030–0090 B

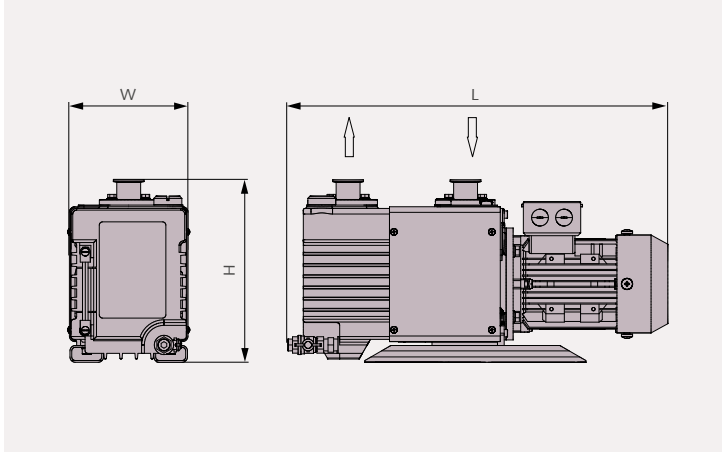

Pumping speed Air at 70 °F. Tolerance: ± 10%

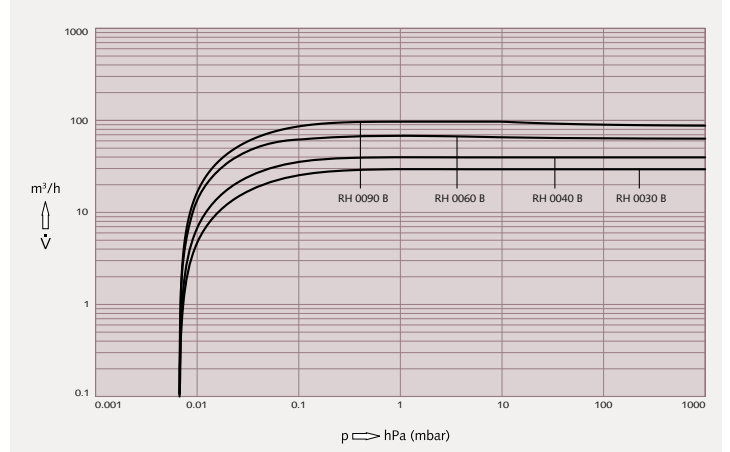

Technical data			RH 0030 B	RH 0040 B	RH 0060 B	RH 0090 B
Pumping speed		m³/h	29	39	65	95
Pumping speed		l/min	483	650	1083	1583
Ultimate partial pressure	Gas-ballast valve closed	hPa (mbar)	$6.7 \cdot 10^{-4}$	$6.7 \cdot 10^{-4}$	$6.7 \cdot 10^{-4}$	$6.7 \cdot 10^{-4}$
Ultimate total pressure	Gas-ballast valve closed	hPa (mbar)	$6.7 \cdot 10^{-3}$	$6.7 \cdot 10^{-3}$	$6.7 \cdot 10^{-3}$	$6.7 \cdot 10^{-3}$
Ultimate total pressure	Gas-ballast valve open	hPa (mbar)	$2 \cdot 10^{-2}$	$2 \cdot 10^{-2}$	$2 \cdot 10^{-2}$	$2 \cdot 10^{-2}$
Max. continuous inlet pressure		hPa (mbar)	65	65	65	10
Max. back pressure (gauge)		hPa (mbar)	300	300	300	300
Water vapor capacity	Gas-ballast valve open	g/h	250	410	1100	600

Motor data three-phase version						
Nominal motor rating		kW	1.5	1.5	2.2	3.7
Energy efficiency class			IE3	IE3	IE3	IE3
Operating voltage		V	200–240 / 380–460	200–240 / 380–460	200–240 / 380–460	200–240 / 380–460

Physical data						
Ambient temperature		°F	39–104	39–104	39–104	39–104
Oil			VMA 055	VMA 055	VMA 055	VMA 055
Oil capacity		l	2.5	2.5	4	4
Sound level (ISO 2151)		dB(A)	< 61	< 64	< 64	< 66
Approximate weight		kg	58	60	90	113
Dimensions (L x W x H)		mm	671 x 214 x 326	691 x 214 x 326	772 x 264 x 373	831 x 264 x 373
Gas inlet / outlet			ISO-KF 40 / ISO-KF 40	ISO-KF 40 / ISO-KF 40	ISO-KF 40 / ISO-KF 40	ISO-K 63 / ISO-KF 40

Applicable standards						
Marking			cTUVus	cTUVus	cTUVus	cTUVus

All performance data is based on ambient conditions of 14.7 PSIA and 70 °F, and has a tolerance of ± 10%.

Busch LLC

516 Viking Drive | Virginia Beach, VA 23452 | Phone 757-463-7800 | info@buschusa.com | www.buschusa.com

Argentina Australia Austria Bangladesh Belgium Brazil Canada Chile China Colombia Czech Republic Denmark Finland France Germany Hungary India Ireland Israel Italy Japan Korea Malaysia Mexico Netherlands New Zealand Norway Peru Poland Portugal Romania Russia Singapore South Africa Spain Sweden Switzerland Taiwan Thailand Turkey United Arab Emirates United Kingdom USA

Technical data is subject to change. Created in Germany. MG PL ZEBRARH003000908 USenU 03/2018 8Aa

Zebra

Two-Stage Rotary Vane Vacuum Pumps RH 0030-0090 B



Article Numbers, Genuine Accessories and Spare Parts	RH 0030 B	RH 0040 B	RH 0060 B	RH 0090 B
With three-phase motor				
200-240 / 380-460, 50/60 Hz	1141168799	1141168800	1141168801	1141168802
Inlet accessories¹				
Inlet filter FIL 0080	0530566434			-
Spare polyester filter element for FIL 0080	0532121862			-
Special purpose filter element for FIL 0080	on request			-
Inlet filter FIL 0350	-			0530168812
Spare polyester filter element for FIL 0350	-			0532121864
Special purpose filter element for FIL 0350	-			on request
Outlet accessories²				
Oil mist separator OMS 0040	0960168806		-	
Spare filter element for OMS 0040	0532169044		-	
Oil mist separator OMS 0090	-		0960168807	
Spare filter element for OMS 0090	-		0532169045	
Oil return line	0946168809			
Other accessories				
Gas-ballast valve	0916168803			
Oil				
VMA 055, 1L	0831169415			
VMA 055, 5L	0831169416			
Maintenance kits				
Minor maintenance kit	0992168950	0992168952	0992168954	0992168956
Major maintenance kit	0993168951	0993168953	0993168955	0993168957

¹ All filters include housing, polyester filter element and mounting hardware
² All oil mist separators include housing, filter element and mounting hardware

Busch LLC

516 Viking Drive | Virginia Beach, VA 23452 | Phone 757-463-7800 | info@buschusa.com | www.buschusa.com

Argentina Australia Austria Bangladesh Belgium Brazil Canada Chile China Colombia Czech Republic Denmark Finland France Germany Hungary India Ireland Israel Italy Japan Korea Malaysia Mexico Netherlands New Zealand Norway Peru Poland Portugal Romania Russia Singapore South Africa Spain Sweden Switzerland Taiwan Thailand Turkey United Arab Emirates United Kingdom USA

Technical data is subject to change. Created in Germany. MG PL ZEBRARH003000908 USenus 03/2018 8Aa