

# SOGEVAC SV 40 BI



SOGEVAC SV 40 BI

## Advantages to the User

- 1 decade better ultimate pressure compared to SOGEVAC SV 40 B
- Integrated exhaust filter
- Integrated oil recovery system and anti suckback valve
- Extremely low noise level
- High reliability
- Variant concept
- Customer specific configurations
- High pumping speed stability at low pressure

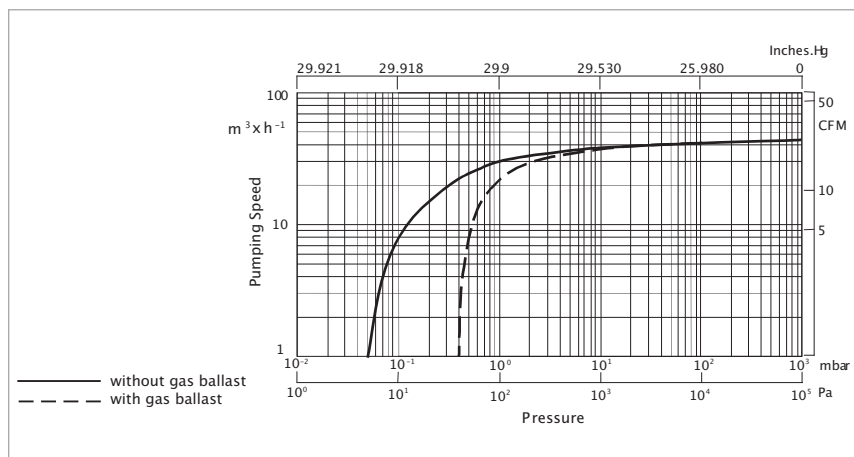

Pumping speed characteristics of the SOGEVAC SV 40 BI at 50 Hz (60 Hz curves at the end of the section)

## Typical Applications

- Mass spectrometry
- Lyophilisation
- Laboratory
- Refrigeration and air-conditioning
- Lamps and bulbs
- ... and more

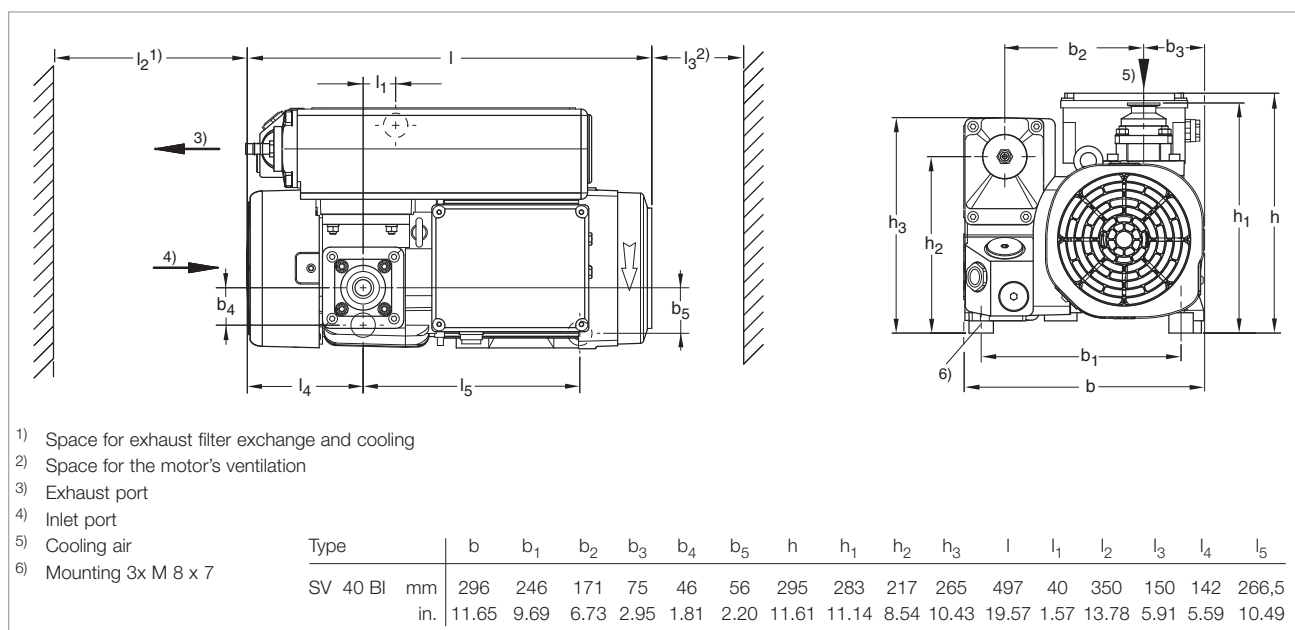

Dimensional drawing for the SOGEVAC SV 40 BI with standard single-phase motor, European version (dimensions for three-phase motor smaller)

## Technical Data

## SOGEVAC SV 40 BI

		50 Hz	60 Hz
Nominal pumping speed	m <sup>3</sup> x h <sup>-1</sup> (cfm)	42 (24.8)	50 (29.5)
Pumping speed (according to PNEUROP)	m <sup>3</sup> x h <sup>-1</sup> (cfm)	40 (23.6)	48 (28.3)
Ultimate partial pressure without gas ballast	mbar (Torr)	≤ 5 x 10 <sup>-2</sup> (≤ 3.75 x 10 <sup>-2</sup> )	≤ 5 x 10 <sup>-2</sup> (≤ 3.75 x 10 <sup>-2</sup> )
Ultimate total pressure with gas ballast	mbar (Torr)	≤ 0.5 (≤ 0.4)	≤ 0.5 (≤ 0.4)
Water vapor tolerable load with gas ballast	kg x h <sup>-1</sup> (qt/hr)	0.28 (0.30)	0.34 (0.35)
Motor power	kW (hp)	1.1 (2.0)	1.3 (2.0)
Mains voltage and frequency	V	see "Ordering Information"	see "Ordering Information"
Rated rotational speed	min <sup>-1</sup> (rpm)	1500 (1500)	1800 (1800)
Type of protection	IP	55-F	55-F
Leak rate	mbar x l x s <sup>-1</sup>	≤ 1 x 10 <sup>-3</sup>	≤ 1 x 10 <sup>-3</sup>
Oil capacity	l (qt)	1.0 (1.1)	1.0 (1.1)
Weight (with oil)	kg (lbs)	43 (94.9)	45 (99.3)
Connections			
intake	DN	40 KF	40 KF
exhaust	DN	40 KF	40 KF

## Ordering Information

## SOGEVAC SV 40 BI 50/60 Hz

SOGEVAC SV 40 BI with three-phase motor without gas ballast 230/400 V, 50 Hz and 460 V, 60 Hz	<b>Part No. 960 330</b>
with small gas ballast 230/400 V, 50 Hz and 460 V, 60 Hz	<b>Part No. 960 331</b>
Other voltages/frequencies or single-phase motors	<b>upon request</b>
Filling with special oil	<b>upon request</b>
Exhaust filter cartridge AFE SV40B	<b>Part No. 714 21 180</b>
Repair kit	<b>Part No. 971 443 150</b>
Set of seals	<b>Part No. 971 427 640</b>
Service kit	<b>Part No. 971 427 660</b>
Vacuum generator with gas ballast	<b>Part No. 971 443 160</b>
without gas ballast	<b>Part No. 971 443 170</b>
For further accessories on pump inlet see Chapter "Accessories for TRIVAC" in the Product Section C01 "TRIVAC"	