

SL Liquid Traps



SOGEVAC SV 40 with SL 40 liquid trap

The SL 16-25 liquid trap consists of a collection vessel made of transparent plastic.

Liquid traps SL 40 to SL 1200 are welded steel collection vessels acting as liquid traps. These are equipped with connecting threads.

Liquid traps SL 630 and SL 1200 are equipped with a cleaning port DN 150 PN 10.

Advantages to the User

- Protection of the pumps against liquids which might condense in the intake or the exhaust line when pumping vapors

Technical Notes

The liquid traps are equipped with a sight glass tube, so that it is easy to determine when to empty the vessels. The liquid drain is sealed by a screw-in cap. This cap may be replaced by a drain valve.

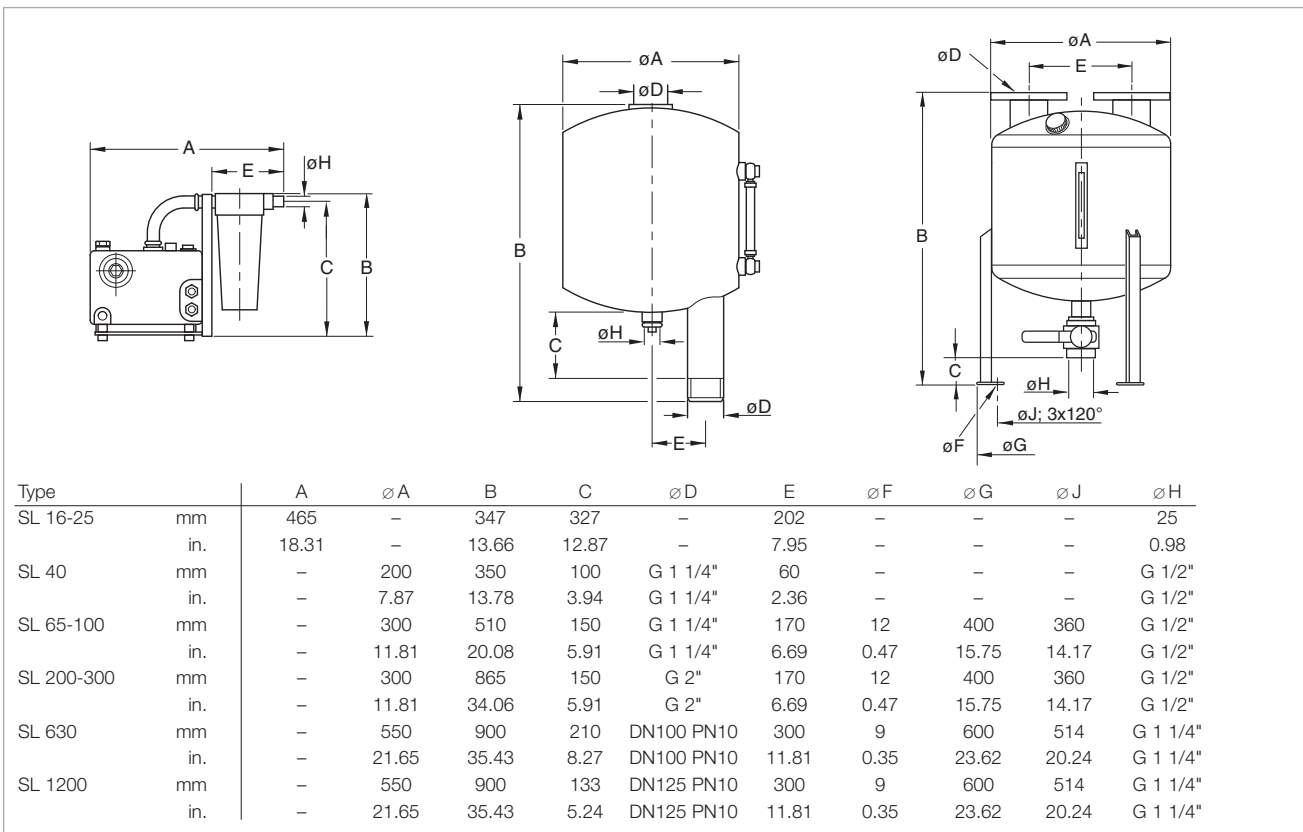

Dimensional drawings for the liquid traps; SL 16-25 (left), SL 40 (middle) and SL 65-100 up to SL 1200 (right)

Technical Data

		SL 16-25	Liquid Traps SL 40	SL 65-100
For pump	SOGEVAC SV	for pumps from 10 to 25 m ³ /h	40 B	40 B/65 B/100 B
Condensate capacity	l (qt)	2.0 (2.1)	4.0 (4.2)	16.0 (16.9)
Weight	kg (lbs)	3.5 (7.7)	5.0 (11.0)	11.0 (24.3)

Ordering Information

		SL 16-25	Liquid Traps SL 40	SL 65-100
Liquid trap		Part No. 951 38	Part No. 951 40	Part No. 951 42
Drain valve		-	Part No. 711 30 111	Part No. 711 30 113

Technical Data

		SL 200-300	Liquid Traps SL 630	SL 1200
For pump	SOGEVAC SV	200/300 (B)	500/630/750 (B)(F)	500/630/750 (B)(F)/1200
Condensate capacity	l (qt)	40.0 (42.3)	80.0 (84.6)	80.0 (84.6)
Weight	kg (lbs)	17.0 (37.5)	58.0 (127.9)	59.0 (130.1)

Ordering Information

		SL 200-300	Liquid Traps SL 630	SL 1200
Liquid trap		Part No. 951 44	Part No. 951 47	Part No. 951 48
Drain valve		Part No. 711 30 113	Part No. 711 30 105	Part No. 711 30 105
Double spigot for drain valve		-	Part No. 711 18 033	Part No. 711 18 033

Only available for purchase in North and South America

Technical Data

		SL 16-25	Liquid Traps SL 40	SL 65-100
For pump	SOGEVAC SV	for pumps from 10 to 25 m ³ /h	40 B	40 B/65 B/100 B
Condensate capacity	l (qt)	2.0 (2.1)	4.0 (4.2)	16.0 (16.9)
Weight	kg (lbs)	3.5 (7.7)	5.0 (11.0)	11.0 (24.3)

Ordering Information

		SL 16-25	Liquid Traps SL 40	SL 65-100
Liquid trap		Part No. 951 38 (BSP)	Part No. 951 40 (NPT) and 2x Part No. 710 35 073	Part No. 951 43 (NPT)
Drain valve		-	Part No. 711 30 111	Part No. 711 30 113

Technical Data

		SL 200-300	Liquid Traps SL 630	SL 1200
For pump	SOGEVAC SV	200/300 (B)	500/630/750 (B)(F)	500/630/750 (B)(F)/1200
Condensate capacity	l (qt)	40.0 (42.3)	80.0 (84.6)	80.0 (84.6)
Weight	kg (lbs)	17.0 (37.5)	58.0 (127.9)	59.0 (130.1)

Ordering Information

		SL 200-300	Liquid Traps SL 630	SL 1200
Liquid trap		Part No. 951 45 (NPT)	Part No. 951 47 (BSP)	Part No. 951 48 (BSP)
Drain valve		Part No. 711 30 113	Part No. 711 30 105	Part No. 711 30 105
Double spigot for drain valve		-	Part No. 711 18 033	Part No. 711 18 033