

A1529-5-ISO

REV
5/2/2013

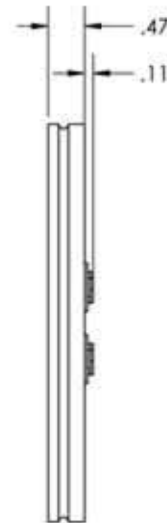
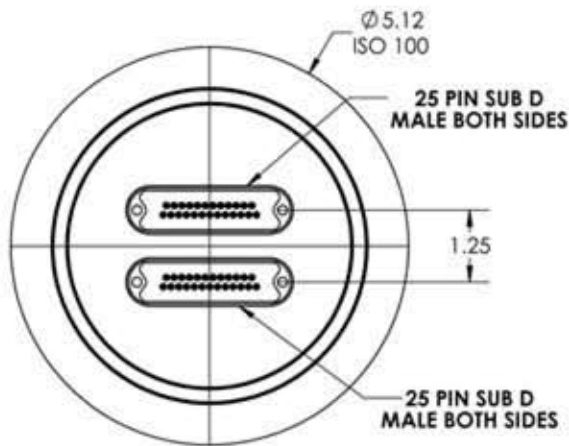

APPROVED

Subminiature D-type Multipin Feedthrough, 2 x 25 Pins, 500 Volts, 5 Amps per Pin, 5.12" ISO Flange

TITLE:

MULTIPIN, TYPE-D, 500V, 5A
2 x 25 PIN, ISO100

PROPRIETARY AND CONFIDENTIAL		UNLESS OTHERWISE SPECIFIED:		MPF PRODUCTS INC.		
ANY REPRODUCTION IN PART OR AS A WHOLE WITHOUT THE WRITTEN PERMISSION OF MPF PRODUCTS INC. IS PROHIBITED.	DIMENSIONS ARE IN INCHES TOLERANCES: ANGULAR: MACH ± 1/2 ° TWO PLACE DECIMAL THREE PLACE DECIMAL		FINISH	DRAWN BY	JB	DATE
			ISO FLANGE	CHECKED		
USED ON:			DO NOT SCALE DRAWING	ENG APPR.	JB	

SIZE	DWG. NO.	REV
A	A1529-5-ISO	5/2/2013
LAST SAVED DATE	Thursday, April 25, 2013 8:54:20 AM	