

A0656

REV  
5/28/2013

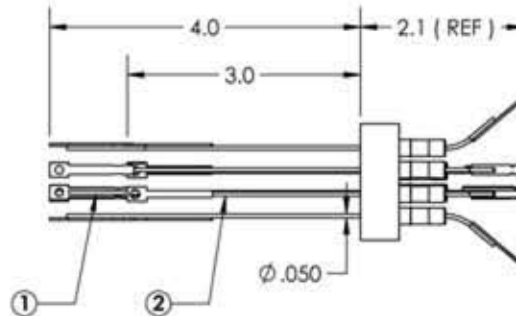

PART #	T/C TYPE	ITEM # 1 (-) LONG	ITEM # 2 (+) SHORT
A0656-1-W	K	ALUMEL	CHROMEL
A0656-2-W	J	CONSTANTAN	IRON
A0656-3-W	C	ALLOY 426	ALLOY 405
A0656-4-W	E	CONSTANTAN	CHROMEL

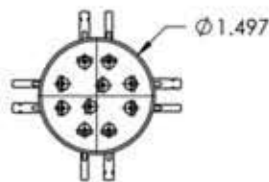
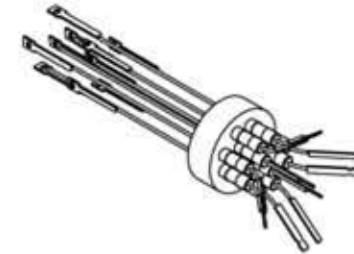
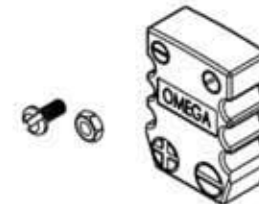

APPROVED

Thermocouple Feedthrough 5 Pairs, Miniature Connectors, 1.50" Dia Stainless Steel Weld Adapter

TITLE:  
THERMOCOUPLE 5 PAIR  
CONNECTOR, WELD

<b>PROPRIETARY AND CONFIDENTIAL</b>		<b>UNLESS OTHERWISE SPECIFIED:</b>		<b>MPF PRODUCTS INC.</b>		
ANY REPRODUCTION IN PART OR AS A WHOLE WITHOUT THE WRITTEN PERMISSION OF MPF PRODUCTS INC. IS PROHIBITED.  USED ON:	DIMENSIONS ARE IN INCHES TOLERANCES:  ANGULAR: MACH ± 1/2 ° TWO PLACE DECIMAL THREE PLACE DECIMAL		FINISH	DRAWN BY	JB	DATE
			<b>WELDABLE</b>	CHECKED		
			DO NOT SCALE DRAWING	ENG APPR.	JB	

SIZE	DWG. NO.	REV
<b>A</b>	<b>A0656</b>	
LAST SAVED DATE	Thursday, May 09, 2013 9:58:58 AM	